

FEATURES

- RoHS compliant, single-port serial communications adapter for USB 2.0 or 3.0
- Supports multi-drop RS-485 protocol
- Includes type FT232R UART with 128-byte receive/256-byte transmit FIFO buffers
- Speeds up to 3Mbps asynchronous
- Supports 7 or 8 data bits, 1 or 2 stop bits, and odd / even / mark / space / no parity
- $\pm 15\text{kV}$ ESD Protection (IEC 6100) on RS-485 signals
- All required power drawn from host USB port, no external power adapter required
- Compact, industrial, metal backshell
- Operating temperature of -40° to $+85^{\circ}\text{C}$
- Supported for use in Windows CE

FACTORY OPTION

- -Term RC Termination

APPLICATIONS

- Scales
- Data entry terminals
- Data acquisition and automation modules
- Transportation



FUNCTIONAL DESCRIPTION

The USB-485-IND is a rugged industrial serial communications adapter designed for use in demanding real-world applications such as transportation, military embedded control systems, remote data acquisition, mobile, and more. This intelligent module provides a cost-effective solution for transferring high-speed asynchronous serial data over USB. The adapter provides easy connectivity between the computer and standard communication ports or remote serial devices. No PC reconfiguration, assignment of IRQs, or jumper settings required. The adapter will be recognized as a USB to Serial Adapter and install in the system as a standard COM port.

ACCESSORIES

The module is available with an optional screw terminal adapter board model ADAP9 to break out signals for ease of connection.

SOFTWARE

The USB-485-IND is a plug-and-play device using the built in OS drivers which allows quick connect or disconnect without having to fumble with locating driver media whenever you need an RS-485 port. The USB-485-IND is supported for use in most USB supported operating systems and includes a free Linux and Windows compatible software package. The software package includes sample programs and source code in C#, Delphi, Visual Basic, and Visual C++ for Windows.

SPECIFICATIONS

Communications Interface

Serial Port: RS-485
 Connector: DB-9 Male
 Character Length: 7 or 8 bits
 Parity: Even, odd, mark, space or none
 Stop Interval: 1 or 2 bits
 Serial Data Rates: 300bps up to 3Mbps asynchronous
 In/Output Voltage: $\pm 14V$
 Rcvr Input Sens.: $\pm 200mV$
 Termination: 120Ω w/ $0.01\mu F$ capacitor (Factory Option)
 Bias: Transceiver lines via $10k\Omega$
 ESD Protection: $\pm 15kV$ on all signal pins

Bus Type

USB 2.0 Full-Speed
 USB 3.0 Compatible

Environmental

Operating Temp: -40° to $+85^{\circ}C$
 Storage Temp: -65° to $+150^{\circ}C$
 Humidity: 5% to 95%, non-condensing
 Power Required: 5VDC at $\sim 11mA$ with no load
 Cable Length: 6 feet
 Backshell Dim.: $1.236'' \times 0.657'' \times 2.094''$
 ($31.4mm \times 16.7mm \times 53.2mm$)

Ordering Guide

USB-485-IND USB to RS-485 industrial serial adapter
 USB-485-IND-TERM As above, including termination

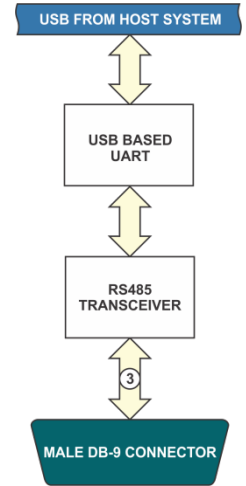

BLOCK DIAGRAM

PIN	DB9M
1	-TX/RX
2	+TX/RX
3	-TX/RX
4	
5	GND
6	
7	
8	
9	+TX/RX

Pinout Table

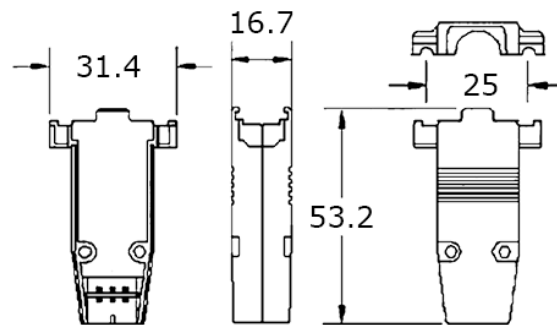

Units: mm ± 0.5

Backshell Drawing

